



Technical Information

## EnDat 3: Proven Interface Technology Continuously Further Developed

EnDat is the ideal interface for digital drive systems and position control loops with position encoders for measurement feedback. Transmission over its serial interface is both fast and dependable, and can also include additional data such as motor-specific parameters and sensor information. Its extensive diagnostics and the inclusion of encoders in troubleshooting routines ensure high system reliability.

These features and benefits have established EnDat as a standard and globally recognized interface for position encoders in the machine tool, electronics, and automation industries. With a broad, multi-supplier portfolio of encoders featuring various measuring principles, machine and equipment manufacturers are sure to find the right EnDat encoder for their specific application and requirements.

EnDat 3 carries forward the features and benefits of EnDat into the future of digital manufacturing. To achieve this feat, EnDat 3 relies on a new architecture that not only preserves proven technology but also maintains the best possible continuity and compatibility with previous versions.

What's new with EnDat 3:

- Hybrid cable transmission
- Bus topologies
- Sensors: flexible data contents and sensor box
- Functional safety: black-channel communication
- Higher data bandwidth
- Definable send lists
- System installation: introduction of access levels

The graphic features a green background with a white curved arrow pointing to the text "EnDat 3". To the left of the text is a list of five features, each with an icon: "Universal" (a three-way fork), "High-performance" (a speedometer), "Communicative" (a double-headed arrow with binary code), "Diagnostics-capable" (a stethoscope), and "Safe" (a Functional Safety logo). To the right of the text is a detailed image of a metal position encoder.

## EnDat 3

- Universal**
- High-performance**
- Communicative**
- Diagnostics-capable**
- Safe**

# EnDat 3: future-ready for digital manufacturing

## Inception: EnDat 2.1

The EnDat story began in 1995 with the introduction of EnDat 2.1. This first EnDat version boasted the following features right from the get-go:

- Automatic system installation
  - Electronic ID label
  - OEM memory
  - Datum shifting
- Alarms and warnings

## Purely serial: EnDat 2.2

The introduction of EnDat 2.2 in 2003 was marked by the transition to purely serial data transmission and a strong focus on continuity with the previous version. EnDat 2.2 also added functionality in the following areas:

- Functional safety
- Temperature sensors
- Online diagnostics (function reserve)
- HMC 6 hybrid cable technology
- Support of additional encoder types (e.g., with buffer battery backup)

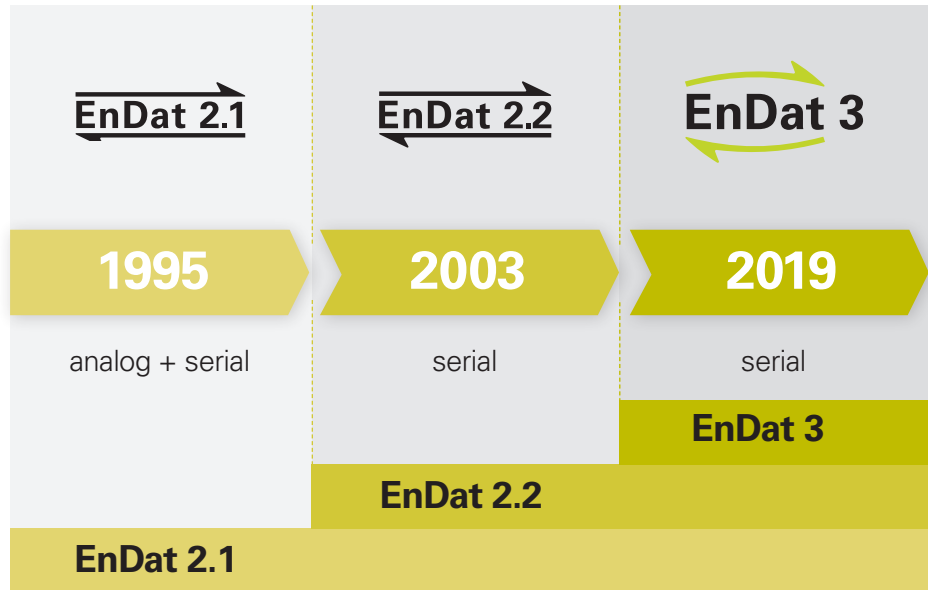

## Future-ready: EnDat 3

The arrival of EnDat 3 on the market marks a new interface generation that continues to develop and expand on the features of the EnDat family for the digital future of industrial manufacturing:

### Universal

- Wide range of encoders from various manufacturers
- Convenient cabling
  - HMC 2 hybrid cable technology
  - Bus operation
  - Integration of sensor boxes
- Integration of additional sensors
  - Sensors integrated into the encoder
  - External sensors

### High-performance

- Short cycle times
  - 15  $\mu$ s attainable with low position-measurement jitter
- High bandwidth
  - 12.5 Mbps at 100 m cable length or 25 Mbps at 40 m

### Communicative

- Transmission of position values and sensor data
  - Send lists permit predefined communication for various operating scenarios
  - Access to encoder memory during normal operation
- Extensive system monitoring for Industry 4.0
  - Automatic system installation and diagnostics
  - Sensor data

### Diagnostics-capable

- Electronic ID label for automatic system installation
  - Data for encoder, motor, and system
- Online encoder diagnostics
  - Together with the sensor data, forms the basis for condition monitoring and predictive maintenance
- Storage of operating status data
  - Storage via the subsequent electronics
  - Data acquisition through the encoder

### Safe

- For safety-related applications up to SIL 3
  - Black-channel communication
  - Easy implementation thanks to data separation for motion controller and safety controller



Thanks to the broad portfolio of EnDat 2.2 encoders, an optimal encoder is available for any given application:

- Encoders with different measuring and scanning methods
  - Absolute, incremental
  - Photoelectric, inductive, magnetic
  - Singleturn, multiturn with gears, multiturn with buffer battery backup
- Encoders with compatible mounting solutions

The product portfolio for EnDat 3 is being similarly developed.

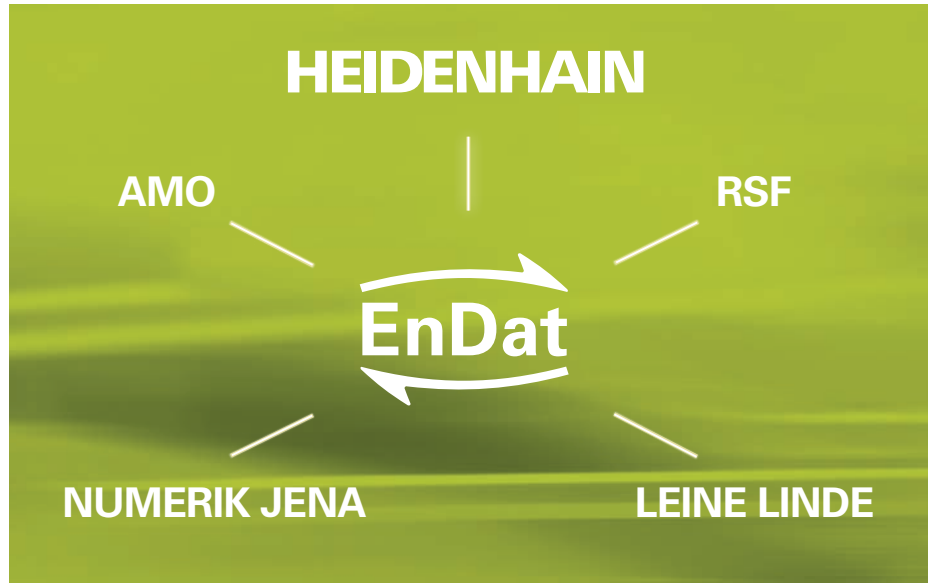

**The main industries for which EnDat was originally designed, and for which EnDat 3 is being further developed, stand to benefit in particular from the following features:**

**Automation**

- HMC 2 hybrid cable
- Bus operation
- Sensor integration (e.g., easy connection of a temperature sensor inside the servomotor, with characteristic curve selection for a KTY 84-130 or PT 1000)
- Acquisition and storage of operating status data
- System information for automatic configuration
- Diagnostic capabilities
- Functional safety

**Machine tool**

- Mechanically robust cabling
- Integration of complex sensors and sensor boxes
- Multi-dimensional measurement technology
- System information for automatic configuration
- Diagnostic capabilities
- Functional safety

**Electronics industry**

- Weight reduction due to thinner cables and bus operation
- Multi-dimensional measurement technology
- System information for automatic configuration
- Diagnostic capabilities

This complex block features a central yellow diagonal banner with the following text:
 

- Future-ready technology
- Machine design flexibility
- Wide range of encoders

 Surrounding the banner are three hexagonal images: a robotic arm on the left, a machine tool in the center, and a control cabinet on the right. The background is a green-to-yellow gradient. The website address 'www.endat.de' is located in the bottom right corner of the block.

The features of the EnDat interface and the wide range of available encoders permit the implementation of machine design flexibility with future-ready technology.

# EnDat 3: overview of basic features

Interface	
<b>Protocol</b>	Request-response method in half-duplex mode
<b>Physical layer</b>	RS-485: 4-wire or 2-wire
<b>Data rate</b>	12.5 Mbps (25 Mbps)
<b>Cable length</b>	For 12.5 Mbps: max. 100 m / for 25 Mbps: max. 40 m
<b>HPF send time</b> (position availability in the master)	Typically 10 $\mu$ s
<b>Cycle time</b>	Typically > 25 $\mu$ s
<b>Bus operation</b>	Daisy chain
<b>Functional safety</b>	Designed for up to SIL 3, black-channel communication

Functions	
<b>Diagnostics</b>	For condition monitoring and predictive maintenance
<b>System information</b>	Automated configuration and storage of operating status data
<b>Access control</b>	User authentication (e.g., for datum shift, OEM memory)

## Ordering designations

The ordering designation defines key communication characteristics

Supported communication types	E30-R2	E30-R4	E30-RB
EnDat 3: communication modulated onto power supply wires	✓	–	–
EnDat 3: communication + separate power supply wires (4 wires)	–	✓	✓
EnDat 3: bus operation	–	–	✓
Sensor box integration	–	✓	✓

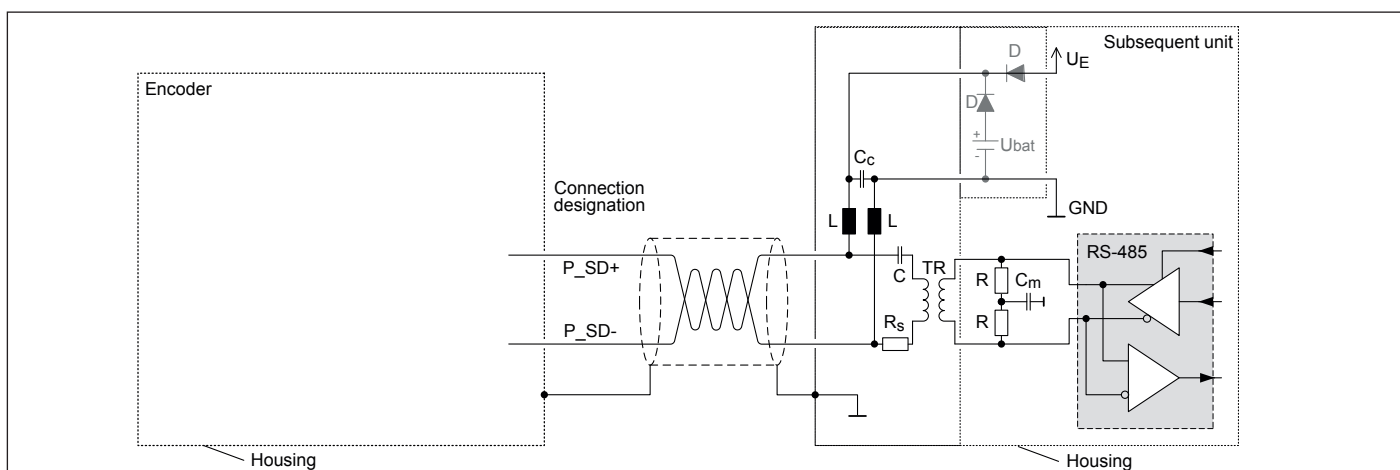

Block diagram: 2-wire

# EnDat 3: communication

EnDat 3 requires two wires for communication, and usually uses two additional wires for encoder power. However, since the digital data stream has no DC component, communication can be modulated onto the supply wires, thereby reducing the overall number of wires to just two for certain applications (e.g., hybrid motor cables). The EnDat 3 interface specification follows an OSI-based layer model.

The encoder side of the interface is referred to as the slave, and the subsequent electronics side as the master. Communication occurs in half-duplex mode. A communication cycle consists of a request from the master followed by a response from the slave. The communication between master and slave is subdivided into foreground communication and background communication.

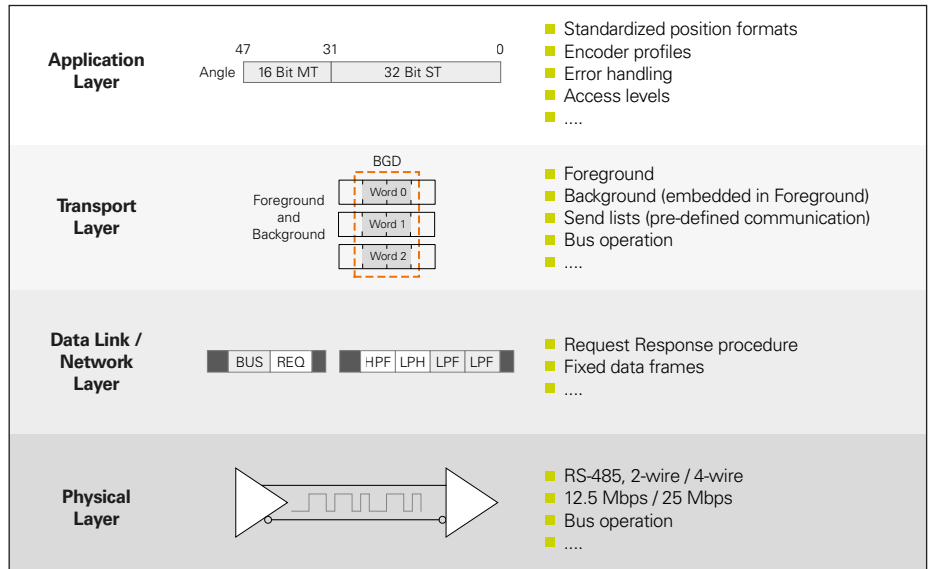

EnDat 3 communication layer model

## Foreground communication

Foreground communication is intended for data that must be available in the communication cycle (e.g., controller cycle).

Requests and responses are structured in frames with a defined length. Each request and response begins with a preamble (PRE) and ends with a postamble (POST). The REQ request frame controls communication with the encoder or triggers certain actions within it (e.g. clearing of error messages) and therefore also determines the contents of the response. Regardless of the REQ frame contents, the response frame is chronologically divided into high-priority data and low-priority data.

A response contains the following elements:

- One HPF (High Priority Frame)  
The HPF typically contains the encoder position. Depending on the encoder, other information can be specified for transmission in the HPF as well.
- One LPH (Low Priority Header)  
The LPH carries status information about the subsequent data contents. It also contains information about the send list and the number of transmitted LPFs. The send list specifies the chronological sequence of LPFs within the individual communication cycles.
- Up to 15 optional LPFs (Low Priority Frames)  
LPFs can carry additional data, such as diagnostic values, sensor information, or redundant information for functional safety.

The LPFs used in EnDat 3 continue to build on the concept of additional data found in EnDat 2.2. The switch between various LPFs is performed in accordance with a send list configured in the encoder's memory. Intervention in the controller cycle by the subsequent electronics is not required. The send list can be configured either in the encoder's volatile memory after each restart or permanently in its non-volatile memory. During operation, the send list specifies which LPFs are to be included in the response from cycle to cycle. Up to eight different send lists can be stored in the memory. The type of request determines which send list is active, thereby allowing the subsequent electronics to react to various operating statuses with speed and flexibility.

A sample communication cycle is shown below. A complete communication cycle always contains the white fields, as well as up to 15 optional LPFs (in gray). Each of the REQ, HPF, LPH, and LPF protocol contents are safeguarded by a CRC (Cyclic Redundancy Check).

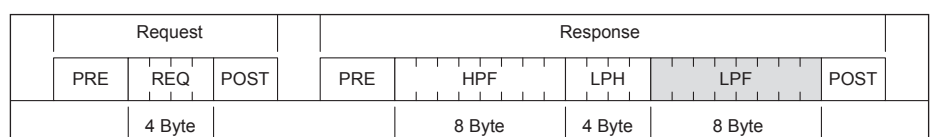

Communication cycle

## Background communication

Some tasks, such as reading from and writing to the encoder memory, have low timing demands. For these kinds of tasks, EnDat 3 defines a background channel. Background communication is embedded in the foreground communication and uses its frames as transport carriers (REQ, LPH, LPF). The background channel thus makes it possible to read from and write to the encoder memory in the controller cycle. However, the background channel cannot handle real-time demands.

## Bus operation

Along with point-to-point operation, EnDat 3 also offers bus operation for special applications. In bus operation, a Bus Request Frame is added in front of the Request Frame, thus allowing multiple participants to send responses in a single communication cycle.



### Further information:

- EnDat 3 Interface Specification



# EnDat 3: communication

## Functional safety

EnDat supports the use of encoders in safety-related applications. This capability is based on the following standards: DIN EN ISO 13849-1 (successor to EN 954-1), as well as EN 61508 and EN 61800-5-2. In these standards, safety-related systems are assessed based on the failure probabilities of integrated components and subsystems, among other criteria. This modular approach helps manufacturers implement their complete systems by allowing them to build upon previously qualified subsystems.

The functional safety provided with EnDat 3 encoders for applications up to SIL 3 is based on the following factors:

- Position value
  - Two independent position values: Pos1 (high resolution) and Pos2 (low resolution, if applicable)
  - Comparison of Pos1 and Pos2 by the safe control unit
- Forced dynamic sampling
  - Cyclic testing of the monitoring function in the encoder
- Error messages
  - Monitoring of error bits F1 and F2
- Due to the black channel, a safe EnDat Master is not required and is thus not part of the safety chain
- Separation of communication to the motion controller and safe control unit (e.g., separate error messages)

*In short, this means the following:*

Convenient implementation is possible thanks to the black-channel approach combined with standardized position data formats and the option of relocating forced dynamic sampling to the encoder.

## Diagnostics

EnDat enables extensive encoder monitoring and diagnostics without an additional wire. Its diagnostics generate valuation numbers, error messages, and warnings, and are a key ingredient in attaining high availability in the complete system.

The important factors:

- Machine utilization planning
- On-site support for the service technician
- Easy evaluation of the encoder's function reserve
- Simplified troubleshooting for repairs
- Generation of useful quality statistics

For analysis of encoder functionality, valuation numbers can be read cyclically from the encoder. Valuation numbers provide information about the current status of the encoder and its function reserve. Because the scaling of valuation numbers is identical for all HEIDENHAIN encoders, consistent analysis is possible. The function reserves, combined with other sensor data, serve as the basis for condition monitoring and predictive maintenance in the higher-level subsequent electronics.

## System information

EnDat makes system information available about the encoder and the system (i.e., electronic ID label):

- Encoder parameters, which are all of the parameters needed for initial encoder configuration, are stored in the encoder.
- System parameters can be stored in the encoder's memory by the OEM or plant builder, and accessible areas can be password-protected.
- System or process status data, referred to as operating status data, can be stored in the encoder during normal operation; the encoder can even acquire operating status data on its own.

## Access control

Memory areas can be protected by various levels of user authentication. The available access levels are OEM1, OEM2, and User. Authentication is performed with a 32-bit password. When the encoder is shipped, the OEM1, OEM2, and User areas are vacant and protectable by separate passwords.

Singleturn and multiturn information can also be separately configured and protected. Typical implementation:

- OEM1 (motor manufacturer): singleturn is set, and OEM1 memory is written to. A password is defined; the OEM1 area is protected.
- OEM2 (machine manufacturer): multiturn is set, and OEM2 memory is written to. A separate password is defined; the OEM2 area is protected.
- User (customer): the User memory can be written to. A separate password is defined; the User area is protected.



### Further information:

- EnDat 3 Application Conditions for Functional Safety

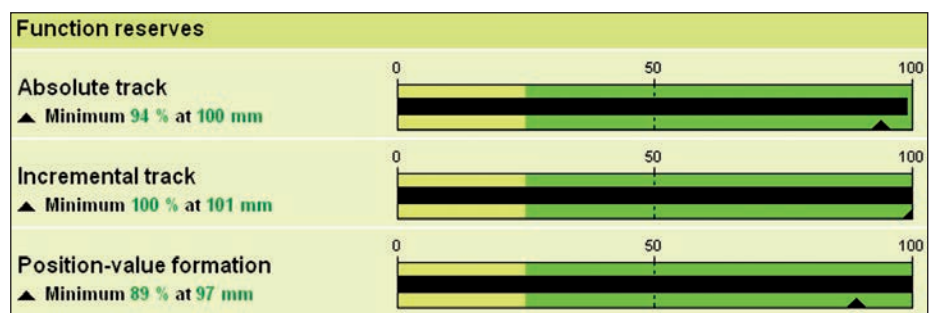

Sample display of the function reserve

# EnDat 3: connection technology

Encoders with the purely serial EnDat interface predominantly use 8-pin M12 and 9-pin M23 connecting elements. This widespread connector technology offers the following benefits:

- Cost-effective connection technology
- Smaller connector dimensions and thinner connecting cables

Through its lower number of wires, EnDat 3 offers further options for miniaturizing the connection technology and adapting it to the application requirements.

## Cables

High transmission frequencies over long cable lengths place rigorous technological demands on the cable. Specifically designed for this purpose, HEIDENHAIN cables are qualified to handle this type of application. We therefore recommend using HEIDENHAIN cables.

## 4-wire technology

In the 4-wire variant, the master powers the encoder with one wire pair and uses a second wire pair to communicate with the encoder.

## 2-wire technology (HMC 2)

Unlike the 4-wire option, the 2-wire variant requires additional hardware. In this configuration, the subsequent electronics both power the encoder and communicate with it along a single wire pair. For this purpose, the encoder power supply and data stream are separated by frequency dividing networks (one on the master and one on the slave).

## 4-wire bus in daisy-chain mode

This variant allows encoders to be operated on a daisy-chain bus. Unlike the 4-wire variant, the 4-wire daisy-chain bus variant requires an additional transceiver branch inside the encoder. This additional transceiver branch establishes the data connection to the next encoder on the bus. The 4-wire daisy-chain bus variant also supports the 4-wire variant.

## Sensor box

With the 4-wire variant, a sensor box can be looped in.

## Power supply

The supply voltage and power consumption are stated in the specifications of each encoder. For encoders with the EnDat 3 interface, a supply voltage of 12 V ( $\pm 5\%$ ) is recommended.

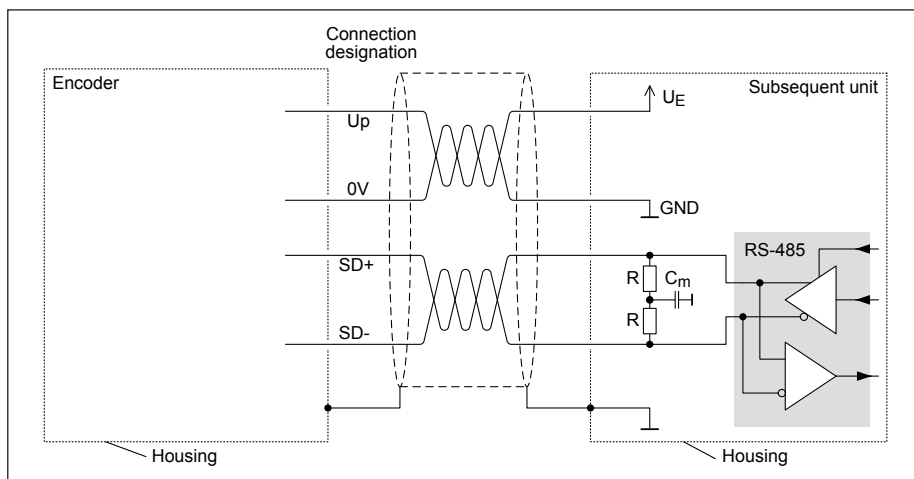

4-wire block diagram



HMC 2 single-cable solution: standard components for a reliable connection



## Further information:

- EnDat 3 Hardware Specification
- Brochure: *Cables and Connectors*
- Product Information doc.: *HMC 6*
- Product Information doc.: *HMC 2*

# Product portfolio with the EnDat 3 interface

## Rotary encoders and connection technology for market introduction:

- ECI/EQI 1100 inductive rotary encoders for small motors
- ECI/EQI 1300 inductive rotary encoders for larger motors
- The HMC 2 hybrid motor cable with an M12 or M23 connector



## HEIDENHAIN

**DR. JOHANNES HEIDENHAIN GmbH**

Dr.-Johannes-Heidenhain-Straße 5

**83301 Traunreut, Germany**

☎ +49 8669 31-0

FAX +49 8669 32-5061

E-mail: [info@heidenhain.de](mailto:info@heidenhain.de)

[www.heidenhain.de](http://www.heidenhain.de)



### Further information on implementation:

The Implementation Guide provides an overview of which documents and their content are intended for which readers, and the available implementation aids.

We would be happy to send you the following EnDat 3 specifications upon request:

- EnDat 3 Interface Specification
- EnDat 3 Hardware Specification
- EnDat 3 Application Conditions for Functional Safety
- EnDat 3 Master Instructions
- EnDat 3 Application Notes

To see the Implementation Guide and submit a query, please visit [www.endat.de](http://www.endat.de)